



Ka-Band Antenna Pointing Guide

1037663-0001
Revision A
March 26, 2008

Revision record

Revision	Date of issue	Scope
A	March 26, 2008	Production Release

Copyright © 2008 Hughes Network Systems, LLC

All rights reserved. This publication and its contents are proprietary to Hughes Network Systems, LLC. No part of this publication may be reproduced in any form or by any means without the written permission of Hughes Network Systems, LLC, 11717 Exploration Lane, Germantown, Maryland 20876.

Hughes Network Systems, LLC has made every effort to ensure the correctness and completeness of the material in this document. Hughes Network Systems, LLC shall not be liable for errors contained herein. The information in this document is subject to change without notice. Hughes Network Systems, LLC makes no warranty of any kind with regard to this material, including, but not limited to, the implied warranties of merchantability and fitness for a particular purpose.

Trademarks

Hughes, Hughes Network Systems, and SPACEWAY are trademarks of Hughes Network Systems, LLC. All other trademarks are the property of their respective owners.

Contents

- Chapter 1**
- Introduction1**
- Scope and audience1
- Related instructions1
- Antenna pointing overview1
 - Pointing tools and user interfaces2
 - Global Positioning System (GPS)2
 - Local User Interface (LUI)2
 - DiSEqC Antenna Pointing Tool (DAPT)2
 - Squinter3
 - Pointing procedure summary4
 - Entering installation parameters4
 - Coarse pointing4
 - Fine pointing5
 - Pointing validation5
- Chapter 2**
- Pointing the antenna7**
- Prerequisites7
- Entering installation parameters8
- Coarse pointing13
- Fine pointing17
 - Attaching Squinter type A18
 - Attaching Squinter types B and C21
- Pointing validation25
- Troubleshooting30
- Acronyms and abbreviations33**
- Index35**

Figures

Chapter 1

- 1. DiSEqC Antenna Pointing Tool (DAPT)2
- 2. Squinter types3

Chapter 2

- 3. Connecting the installer laptop to the IDU (HN9000 shown) 8
- 4. Icon to Installation screen9
- 5. Advanced Configuration and Statistics Installation screen9
- 6. Terminal Pointing Info screen12
- 7. Installing the DAPT13
- 8. Adjusting the antenna position16
- 9. Attaching squinter type A18
- 10. Positioning the squinter properly19
- 11. Attaching squinter types B and C21
- 12. Weatherproofing the cable connectors29

Tables

Chapter 2

1. Installation parameter B Codes.	10
2. Installation parameter C Codes.	10
3. Determining which squinter to use.	17
4. DAPT display messages	30

Chapter 1

Introduction

Scope and audience

This document describes the HughesNet Ka-band antenna pointing procedure. This document is written for professional installers who have experience with installing and pointing satellite antennas.

Related instructions

This pointing guide discusses the antenna pointing procedure only. For an explanation of mechanical adjustments on the antenna, see the specific installation guide for the antenna you are installing. A Ka-band radio assembly must be installed with the antenna before pointing.

This guide applies to the following HughesNet System Ka-band antennas: 0.74 m, 0.98 m, 1.2 m, and 1.8 m.

Antenna pointing overview

The antenna pointing procedure is a critical part of the HughesNet antenna installation process. If the satellite modem antenna is not properly pointed toward the satellite, it cannot communicate with the satellite to its full capacity, resulting in a degradation of system performance.

The basic requirement when pointing a HughesNet antenna is to accurately aim the antenna at the satellite to within 0.2 dB maximum loss of reception and 0.45 dB maximum loss of transmission. The HughesNet system uses a narrow Ka-band beam which can be sensitive to pointing errors, and therefore it is critical that the antenna is pointed properly and accurately. Be sure to follow the procedures in this manual *exactly* as written to achieve this goal.

The antenna pointing process is divided into three tasks: *coarse* pointing, *fine* pointing, and *pointing validation*. Under normal conditions and circumstances, a single professional installer can perform this process alone (the one exception is when pointing the 1.8m antenna, which requires two people to install, due to its large reflector.)

Pointing tools and user interfaces

The antenna pointing process makes use of several tools that are used both separately and together during the procedure. These tools are described in the following sections:

Global Positioning System (GPS)

Use a GPS (not supplied) to determine the exact latitude and longitude coordinates of the antenna site. These coordinates are used to determine the correct azimuth and elevation information for the antenna to point at the satellite from its location.

Your GPS receiver must be accurate to within 15 meters. (Most receivers on the market will meet this requirement. Units employing Wide-Area Augmentation System [WAAS] technology provide accuracy to 3 meters.)

The GPS must display latitude and longitude information in the format DD MM.mmm, where DD = degrees, MM = minutes, and mmm = fractional minutes (the unit must display fractional minutes to three significant digits).

Local User Interface (LUI)

The LUI is the satellite modem interface. It is used to enter installation parameters required for pointing the antenna. The LUI also displays the beacon signal strength for monitoring purposes. To access the LUI, you must first connect your laptop to the indoor unit (IDU), then you will use a standard Internet browser (Internet Explorer 6 or higher, or Mozilla 1.8 or higher) to navigate to the LUI. See *Entering installation parameters* on page 8 for the exact procedure.

DiSEqC Antenna Pointing Tool (DAPT)

The DAPT is a two-way digital satellite equipment control (DiSEqC) tool. It has a large back-lit display and three buttons that enable the installer to step through the antenna pointing procedure. Figure 1 shows the DAPT.

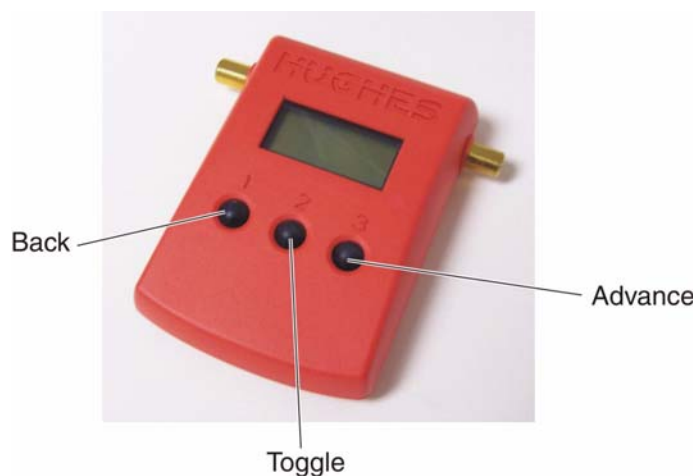

Figure 1: DiSEqC Antenna Pointing Tool (DAPT)

The three buttons on the DAPT can serve different purposes during different phases of the pointing process. In most cases, however, they function as follows:

- *Back* (button 1) – Used to return to a previous state.
- *Toggle* (button 2) – Used to toggle between signal filters.
- *Advance* (button 3) – Used to begin a process, proceed to the next state, or respond *Yes* to a prompt on the DAPT display.

Squinter The squinter is an antenna pointing aid used to electrically fine-point the antenna once coarse pointing is completed. When placed on the antenna feed horn, the squinter inhibits a portion of the RF signal, thereby capturing the satellite signal from different portions of the antenna reflector surface. The squinter is placed alternately in four different positions: two for measuring azimuth and two for measuring elevation. As shown in Figure 2, there are three different types of squinters, each designed for use with specific antennas.



Note: Be sure to use the correct squinter for the antenna you are pointing, as described in Figure 2.



Figure 2: Squinter types

Pointing procedure summary

The antenna pointing process consists of four main steps:

- Entering installation parameters
- Coarse pointing
- Fine pointing
- Pointing validation

This section provides a brief overview of each of these processes. For details, see Chapter 2 – *Pointing the antenna*.

Entering installation parameters

After completing physical installation of the satellite modem hardware, the installer connects a laptop to the satellite modem and accesses the LUI using a standard Internet browser. The installer then enters the satellite modem and antenna installation parameters. These installation parameters include:

- Terminal site name (satellite modem ID)
- Satellite orbital location, or *A Code*
- Antenna size, or *B Code*
- Outdoor unit (ODU) power, or *C Code*
- Satellite ID, or *U Code*
- Latitude and longitude of the antenna site

Once the installer submits these parameters, the satellite modem enters *Pointing* mode. In this mode, the LUI displays the calculated azimuth, elevation, tilt angle, and antenna polarization information required for coarse pointing the antenna.



Note: Azimuth measurements are calibrated relative to *true* north, not magnetic north.

Coarse pointing

After entering the installation parameters, you can begin the process of pointing the antenna at the satellite. Using the proper azimuth, elevation, and tilt coordinates obtained from the LUI, you will point the antenna in the general direction of the satellite to obtain initial acquisition of the satellite signal.



Note: Do *not* attempt to point the antenna manually by pulling on the antenna reflector or the feed support arm. This can cause permanent damage to the antenna.

When the demodulator locks onto the satellite beacon signal, the signal quality factor (SQF) of the received signal-to-noise ratio (SNR) pointing signal appears on the DAPT display in the form of a numerical value from 2 to 255. This value is then used to coarsely find the peak signal level.

Antenna pointing is supported by two filters that help to smooth out the effects of short-term random amplitude fading and phase changes on the received signal, called *scintillation*. Scintillation usually occurs due to changes in atmospheric density caused by fluctuating weather conditions.

The *short* filter is used to quickly find the peak signal level. However, when this filter is used, the signal level will likely be hampered by scintillation. The *long* filter, used to peak the beacon SQF after the satellite has been found, can also be used to dampen the effects of scintillation.

The DAPT enables you to select which of the two filters to use by pressing the DAPT **Toggle** button (button 2). The DAPT display indicates which filter is currently being used with either the letter S (to indicate the short filter) or L (to indicate the long filter).

Fine pointing After locating the satellite and finding the initial peak signal level, you will use the squinter and the fine az/el adjustment mechanism to fine-point the antenna using a *dithering* method. Dithering is a pointing method by which SQF readings are taken from different portions of the antenna reflector. By ensuring that the SQF readings are the same at opposite points on the reflector, this method ensures that the entire reflector is pointing directly at the satellite.

The squinter physically covers one half of the antenna feed horn, inhibiting one half of the signal beam from reaching the antenna reflector. With the squinter placed over the feed horn, the installer takes SQF readings from four positions (two for azimuth and two for elevation); ensuring that readings from opposite sides of the reflector match their counterparts.

When the antenna is pointed correctly, the left azimuth reading will have the same SQF value (within accepted tolerance levels) as the right azimuth reading, and the top elevation reading will have the same SQF value as the bottom elevation reading. (It is not necessary for azimuth readings to match elevation readings.) If the pairs of readings are not within tolerance, the position of the antenna must be adjusted using the fine az/el tool. Once adjusted, you can lock the antenna in position.

Pointing validation After the antenna has been coarse- and fine-pointed, you will complete the installation process by using the DAPT to validate and record the azimuth and elevation measurements.

Chapter 2

Pointing the antenna

This chapter explains the antenna pointing process, and the roles that the LUI, the DAPT, and the squinter play in this process. This chapter contains the following sections:

- *Prerequisites* on page 7
- *Entering installation parameters* on page 8
- *Coarse pointing* on page 13
- *Fine pointing* on page 17
- *Pointing validation* on page 25
- *Troubleshooting* on page 30

Prerequisites

Before pointing the antenna, you must perform the following steps:

1. Assemble and install the antenna at the chosen ODU location following the procedures outlined in the installation guide for the specific antenna model being installed.
2. Install the IDU following the procedures outlined in the installation guide for the specific satellite modem being installed.
3. Run the intra-facility link (IFL) cable between the SAT OUT connector on the IDU and the IFL connector on the antenna radio. For a list of approved cables for the IFL between the antenna and the satellite modem, see the Hughes FSB, ***IFL Cable, Approved List (with lengths) for SPACEWAY Domestic Installations*** (FSB 080111_01A). The FSB lists the maximum cable length for each approved cable type for all relevant radio types.

Entering installation parameters

This section explains how to obtain the proper azimuth and elevation coordinates to point the antenna at the satellite from the antenna site, using the LUI to enter the necessary parameters.

1. Use your GPS to determine the latitude and longitude of the installation site, and record them in the spaces provided below.

Latitude: _____ Degrees ____ Minutes ____ Fractional mins

Longitude: _____ Degrees ____ Minutes ____ Fractional mins

2. Using an Ethernet cable, connect your laptop to the indoor unit (IDU) LAN port as shown in Figure 3.



Note: The laptop must be connected directly to the IDU (without an intervening router).

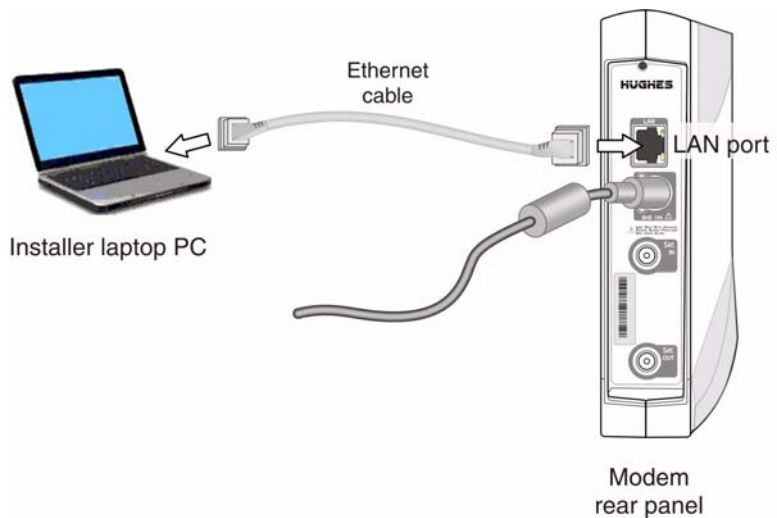

Figure 3: Connecting the installer laptop to the IDU (HN9000 shown)

3. On your laptop, open a web browser (Internet Explorer 6 or higher, or Mozilla 1.8 or higher).
4. Type **169.254.0.1** in the browser address bar and press **Enter**.
5. At the LUI System Control Center home page, click the small icon near the upper right area of the screen, as shown in Figure 4.

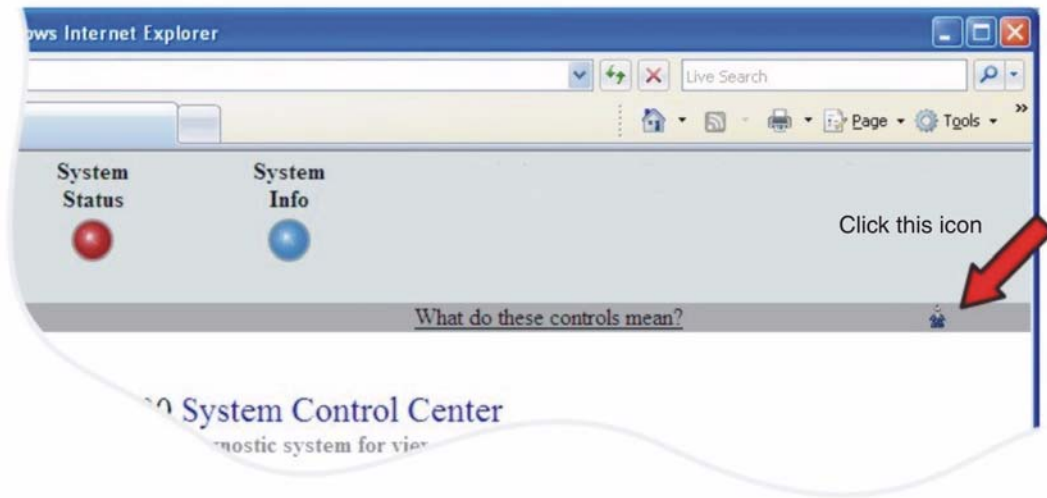

Figure 4: Icon to Installation screen

The Advanced Configuration and Statistics Installation screen appears as shown in Figure 5.

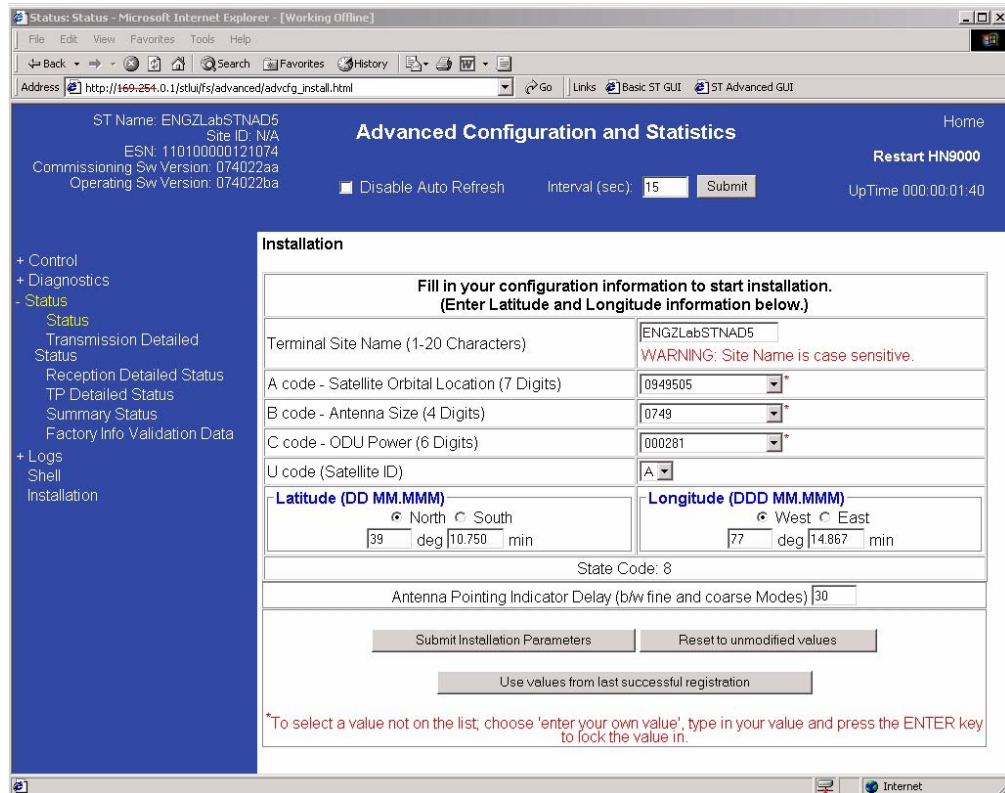

Figure 5: Advanced Configuration and Statistics Installation screen

6. For each of the following installation parameters, select the option from the drop-down menu that matches the value listed on the Installation Reference Sheet.
- Terminal site name. Enter a name for the site up to 20 characters in length.
 - A Code (Satellite orbital location). Select 0949505 from the drop-down menu.
 - B Code (Antenna size). Enter the appropriate code for the antenna, as shown in Table 1.

Table 1: Installation parameter B Codes

B Code	Antenna size
0749	.74 m
0988	.98 m
1208	1.2 m
1804	1.8 m

- C Code (ODU power). Enter the appropriate code for the radio transmitter, as shown in Table 2.

Table 2: Installation parameter C Codes

C Code	Nominal ODU power
000103	1 W
000281	2 W
000501	4 W
001305	10 W (power booster unit used only in certain special configurations)

- U Code (Satellite Unique Word ID). The system supports four Unique Word sets, identified as A, B, C, and D. Contact the field service office (FSO) for the site configuration.



Note: You may overwrite any pre-existing values, but be aware that pointing metrics will be deleted if you change any of the following installation parameters from a previous installation:

- Site latitude
- Site longitude
- Satellite orbital location (A Code)
- Antenna size (B Code)
- ODU power (C Code)
- Satellite Unique Word ID (U Code)

Pointing metrics are also deleted if the satellite modem is uninstalled, although not when it is unregistered.

7. Enter the site latitude and longitude values you recorded from your GPS in step 1.



Note: Do *not* change the Antenna Pointing Indicator Delay value.

8. Click **Submit Installation Parameters**. The IDU saves the information and enters Pointing mode. The Terminal Pointing Info screen appears on the installer laptop as shown in Figure 6.



Note:

1. If you modified any existing parameters, the modem reboots first, and the Terminal Pointing Info screen appears following the reboot.

2. To return to the Installation screen at any time, click **Modify Installation Parameters**.

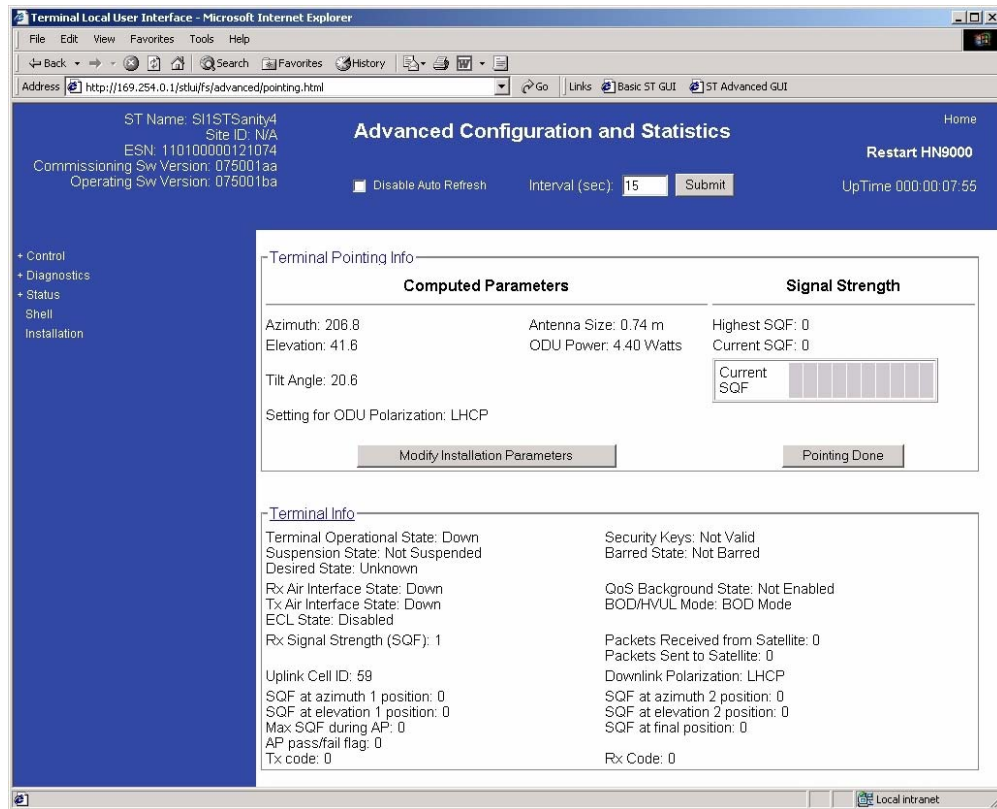

Figure 6: Terminal Pointing Info screen



Note: The initial SQF value listed on this screen will most likely be either 0 or 1, indicating that the demodulator is either initializing or searching for a beacon signal, respectively. Once the demodulator acquires the beacon signal, the SQF value will be greater than 1.

9. Make a note of the following values shown on this screen. You will need this information to point the antenna and complete the installation.
 - Azimuth
 - Elevation
 - Tilt angle (.74m antennas only)
 - ODU polarization setting (LHCP or RHCP).



Note: This is the true polarization setting. Ensure that the polarizer on the antenna radio matches this setting.

Coarse pointing

This section describes each phase of the coarse pointing process and the messages that appear on the DAPT display screen during the procedure.

1. At the ODU, install the DAPT in line with the low-noise block (LNB) converter on the receive cable as shown in Figure 7. Be sure to connect the cables to the DAPT in accordance with the connector labels on the DAPT rear panel (not shown).



Note: You must also ensure that the transmit cable is connected between the SAT OUT connector on the IDU and the IFL connector on the ODU radio transmitter.



Figure 7: Installing the DAPT

When connected properly, the DAPT powers up automatically. Once powered up, the DAPT displays its current status and IFL voltage on the LCD display, as shown below. (Voltage reading shown below is only an example. Actual voltage may vary.)



Note: If the IFL voltage shown is in the neighborhood of 50 volts, the DAPT has mistakenly been connected to the transmit cable instead of the receive cable. Disconnect the DAPT from the transmit cable and connect it to the receive cable before proceeding.

When you press the **Advance** button, the DAPT briefly displays the current software version, as shown below. (The software version shown in the example below is current at the time of this release.)



After a few seconds, the following message appears briefly while the measured IFL voltage is transferred to the IDU:



When the IDU receives the voltage response message, the satellite modem advances to the *Point* state, during which the antenna can be coarse- and fine-pointed. At any time during the Point state, you can select one of two filters to support antenna pointing. The SNR or “short” filter responds quickly to antenna movement, but is also more sensitive to scintillation caused by fluctuating weather conditions. If the SQF readings on the DAPT display vary significantly and do not “settle down” readily, it is usually an indication of high scintillation. The “long” filter is normally used to peak the beacon SQF after the satellite has been found; however, it can also be used to provide more stable feedback during high levels of scintillation.

Upon entering the Point state, the DAPT display reads:



where S or L indicates either the “short” or “long” time constant filter respectively, and SQF is a value from 0 - 255. The left SQF value in row 2 is the highest recorded value during the current phase; the value at right is the current value. For example, the actual display may appear as follows:

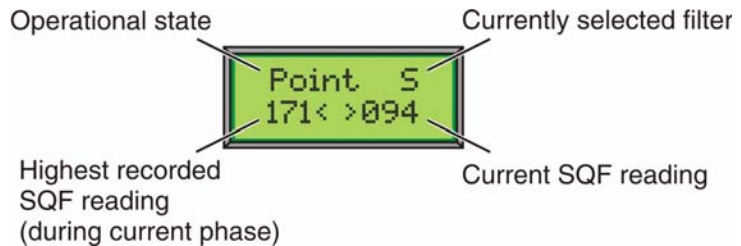

In this example, the short filter is in use (indicated by the S in the top row). The highest recorded SQF value is 171 points, and the current SQF reading is 94 points.

2. Choose either the long or the short filter by pressing **Toggle** (button 2). Each press of this button toggles the selection.
3. Wait for the SQF reading to settle on a value, then use the appropriately sized wrench for the antenna you are pointing to adjust the antenna azimuth and elevation as shown in Figure 8, until you achieve the highest possible SQF value.

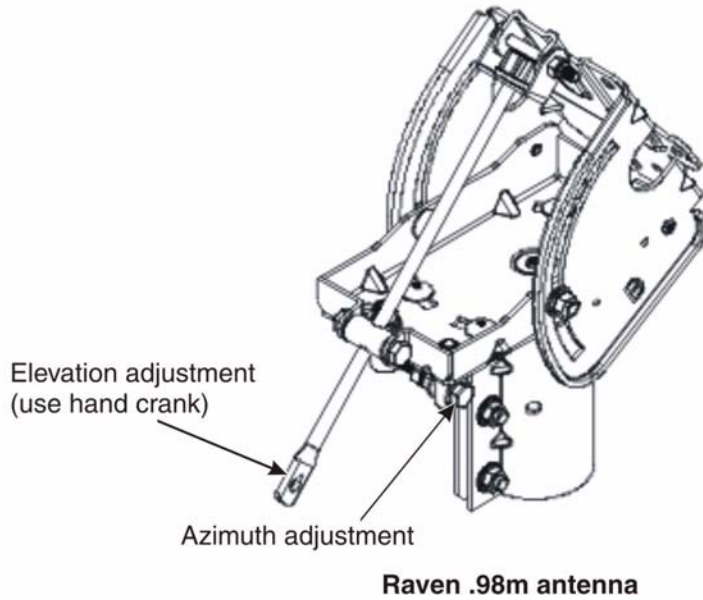
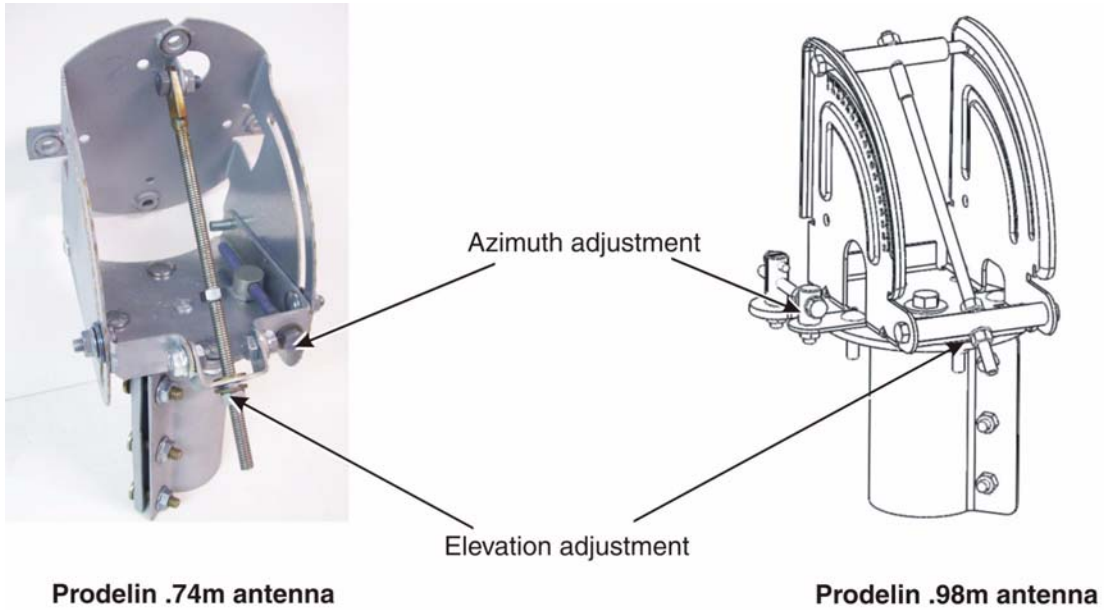

Figure 8: Adjusting the antenna position



Note: You *must* use the adjustment mechanism for coarse azimuth adjustments. Do *not* attempt to point the antenna manually by pulling on the antenna reflector or the feed support structure. This can cause permanent damage to the antenna.

- When the signals are peaked, tighten the azimuth and elevation bolts completely, then loosen the bolts just enough so that you can adjust the azimuth and elevation with the fine azimuth and elevation pointing tools. By tightening the bolts to this level, you can avoid any unwanted movement during antenna lockdown.

Fine pointing

Fine pointing or *dithering* is the process of more accurately pointing the antenna at the satellite. During this phase, the squinter and fine az/el mechanism are used to finely align the antenna and lock it down. The squinter, which blocks off one half of the feed horn, is placed alternately in four different positions on the feed horn, two for measuring azimuth and two for measuring elevation. When the antenna is pointed correctly, the SQF readings at the two azimuth positions will match, and the readings at the two elevation positions will match.

The following steps describe the fine-pointing process.

- Place the appropriate squinter for the antenna on the feed horn. Refer to Table 3 below to determine which squinter you should use, then follow the appropriate procedure.

Table 3: Determining which squinter to use

Antenna	Squinter Type	Hughes Part Number
Prodelin .74m antenna (elliptical feedhorn)	A	1501447
Prodelin .98m, 1.2m, or 1.8m antenna (circular feedhorn)	B	1501454
Raven .74m or .98m antenna (circular feedhorn)	C	1501451



Note: Squinters are available in three sizes to accommodate all of the antenna dish sizes. Be sure to use the correct squinter for the antenna as listed in Table 3.

The process for attaching the different squinters and taking readings will vary slightly, depending on the reflector size and shape.

Attaching Squinter type A

- a. To attach squinter type A, place the squinter on the elliptical feed horn so that the four guide pins on the rear of the squinter lock securely around the feed horn rim, as shown in Figure 9.

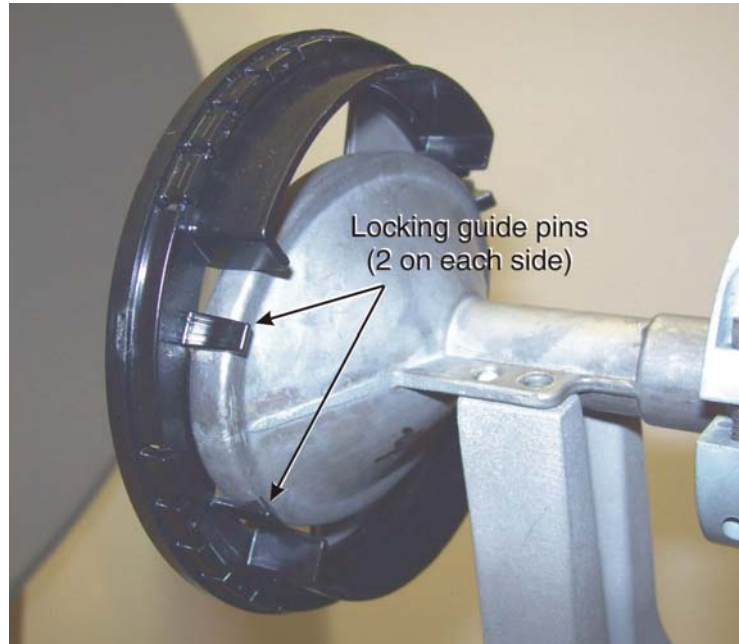

Figure 9: Attaching squinter type A

- b. Rotate the outer piece of the squinter until the bubble in the horizontal (azimuth) level is centered. This is the first azimuth position. The bubble *must* be at the center to ensure that the fine adjustment is correct.



Note: You *must* set the squinter so that it is level, as shown in Figure 10, rather than in line with the plane of the elliptical feed horn. If you set the squinter in line with the feed horn, any adjustments you make will affect both azimuth and elevation.

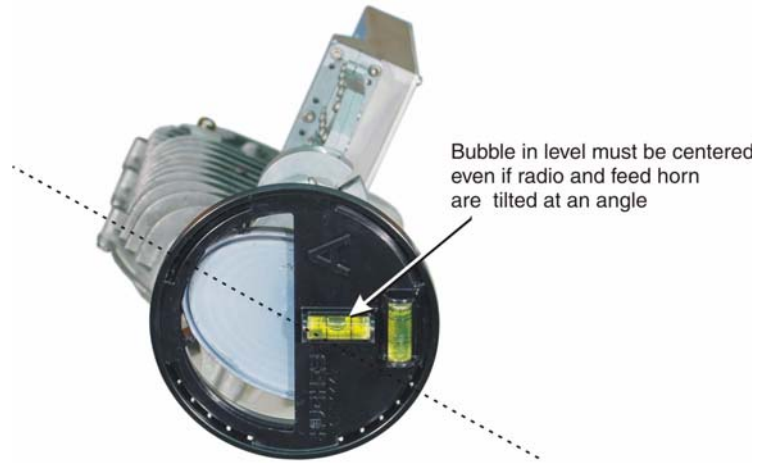

Figure 10: Positioning the squinter properly

- c. Wait for the SQF reading to settle on a value. (The time required is a function of whether you are using the short filter or the long filter.) When the reading has settled, note the SQF value on the display.



Note: If using the short filter, you must wait at least 3 seconds at each dither point. If you do not wait before recording the reading, the pointing signal may not have reached its steady-state value, and will cause a pointing error. If you use the long time constant filter, you should wait at least 15 seconds to take a reading.

- d. Rotate the outer piece of the squinter 180 degrees on the feed horn to the opposite azimuth position, until the bubble is centered again, then check the reading.
- e. Compare the two SQF readings. They should be as close as possible to within 5 SQF points. Continue to adjust the azimuth using the fine az/el tool, and take pairs of azimuth readings until the two azimuth values are within the tolerance level of 5 SQF points.



Note: The tolerance level after antenna lockdown is 15 SQF points. However, the position of the antenna will shift during lockdown, so you will need to get within 5 points at this time to compensate.

- f. Repeat steps b through e for the two elevation positions, using the bubble in the elevation level to accurately position the squinter.

- g. When the pair of elevation readings matches, check the azimuth readings again to ensure that they were not altered during elevation adjustment. Make any adjustments as necessary.
- h. Lock down the azimuth using a socket wrench with an extension.
- i. Measure the top and bottom elevation readings again to ensure that they have not been altered during azimuth lockdown.



Note: Because slight movement of the antenna occurs during lockdown, always measure the elevation readings again after locking down the azimuth. When this second pair of elevation readings matches, you can lock down the elevation.

- j. Lock down the elevation. After lockdown, the two azimuth readings and the two elevation readings should be within 15 points of each other.
- k. When finished, press **Advance**. The DAPT display should read:



Note: It could take anywhere from 2 to 10 minutes before this message appears.

When the `FindSys done` message appears, proceed to step 2 on page 23.

The following message may also appear:



This message indicates that an error has occurred. If this message appears, you must resubmit the installation parameters at the IDU and restart the pointing process, beginning with coarse pointing.

Attaching Squinter types B and C

- a. To attach squinter types B and C, place the squinter on the feed horn, making sure that the four keys around the perimeter of the feed horn fit inside the corresponding grooves on the inside edge of the squinter, as shown in Figure 11.

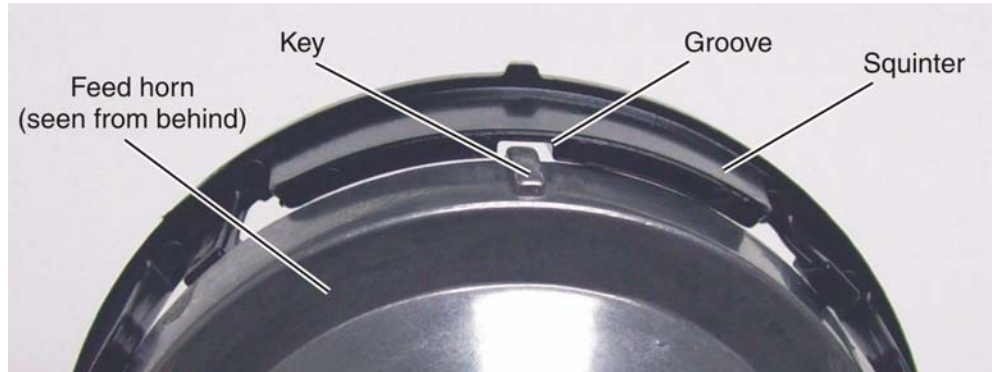

Figure 11: Attaching squinter types B and C

- b. Once the squinter is attached to the feed horn, loosen the two-piece collar that connects the feed horn to the radio assembly and plumb the elevation plane by rotating the feed horn until the bubble in the squinter level is centered; then re-tighten the collar around the feed horn stem. This is the first azimuth position.



Note: When reconnecting the collar, be sure that the point where the two halves of the collar meet lines up with the seam on top of the polarizer waveguide.

- c. Wait for the SQF reading to settle on a value. (The time required is a function of whether you are using the short filter or the long filter.) When the reading has settled, note the SQF value on the display.



Note: If using the short filter, you must wait at least 3 seconds at each dither point. If you do not wait before recording the reading, the pointing signal may not have reached its steady-state value, and will cause a pointing error. If you use the long time constant filter, you should wait at least 15 seconds to take a reading.

- d. Remove the squinter from the feed horn, rotate it 180 degrees to the opposite azimuth position, and replace it on the feed horn, again making sure that the four grooves fit over the feed horn keys.
- e. Wait for the SQF reading to settle on a value and check the reading at this position.
- f. Compare the two azimuth readings. They should be as close as possible to within 5 SQF points. Continue to adjust the azimuth and take pairs of readings until the two azimuth numbers are within the tolerance level of 5 SQF points.



Note: The tolerance level after antenna lockdown is 15 SQF points. However, the position of the antenna will shift during lockdown, so you will need to get within 5 points at this time to compensate.

- g. Remove the squinter from the feed horn, rotate it 90 degrees to the first elevation position, and place it back on the feed horn, again making sure that the four grooves fit over the feed horn keys.
- h. Wait for the SQF reading to settle on a value and note the SQF value on the display.
- i. Remove the squinter from the feed horn, rotate it 180 degrees to the opposite elevation position, and replace it on the feed horn, again making sure that the four grooves fit over the feed horn keys.
- j. Wait for the SQF reading to settle on a value and check the reading at this position.
- k. Continue to adjust the elevation and take pairs of readings until the two elevation values are within the tolerance level of 5 SQF points.
- l. When the pair of elevation readings is within 5 SQF points, check the azimuth readings again to ensure that they were not altered during elevation adjustment. Make any adjustments as necessary using the fine az/el tool.
- m. Lock down the azimuth.
- n. Measure the top and bottom elevation readings again to make sure that they have not been altered during azimuth lockdown.



Note: Because slight movement of the antenna occurs during lockdown, always measure the elevation readings again after locking down the azimuth. When this second pair of elevation readings matches, you can lock down the elevation.

- o. Lock down the elevation. After lockdown, the two azimuth readings and the two elevation readings should be within 15 points of each other.
- p. When finished, press **Advance**. The DAPT display should read:



When the FindSys done message appears, proceed to step 2, below.

The following message may also appear:



This message indicates that an error has occurred. If this message appears, you must resubmit the installation parameters at the IDU and restart the pointing process, beginning with coarse pointing.

- 2. To continue, remove the squinter from the feed horn and press **Advance** to proceed to pointing validation. The following message appears on the DAPT display:



where S or L indicates either the “short” or “long” time constant filter respectively, and SQF is a value from 0 - 255. The left value in row 2 is the highest recorded value during this phase; the value at right is the current value.

- 3. Press **Advance**. One of the following two messages will appear:



This message indicates that the DAPT is ready for you to take the first pointing validation reading. Proceed to *Pointing validation* on page 25.

If, however, final cell selection has not yet been performed, or if the registration megafame initialization packet (MIP) has not been received, the DAPT may instead display the following message:

A rectangular box with a green background and a black border. The text inside is "FindSys" on the top line and "StatusX" on the bottom line.

where X is a number from 1 to 7. This message indicates that the IDU is checking the installation parameters for specific information. If the search is successful, the following message appears when the search is complete:

A rectangular box with a green background and a black border. The text inside is "FindSys" on the top line and "done" on the bottom line.

Press **Advance** and continue with step 2 above.

If the search fails, the following message appears:

A rectangular box with a green background and a black border. The text inside is "FindSys" on the top line and "Failed" on the bottom line.

This message indicates that an error has occurred. You must resubmit the installation parameters at the IDU and restart the pointing process, beginning with coarse pointing.

The following message may also appear:

A rectangular box with a green background and a black border. The text inside is "TxPol" on the top line and "Left" on the bottom line.

This message indicates that the circular polarization must be reversed. During cell selection, it is possible that the closest working cell is in an adjacent uplink (UL) cell, which requires reversing the circular polarization at the antenna. If this message appears, you must change the circular polarization on the transmitter. See *Troubleshooting* on page 30 for more information.



Note: If you change the circular polarization, you must fine-point the antenna again.

Pointing validation

During the pointing validation phase, you will record the final dither readings and compare them to pointing accuracy thresholds. The DAPT walks you through this process, displaying the appropriate squinter position to use for each step.



Note: Because you will be close to the feed horn when adjusting the squinter during the pointing validation tests, it is likely that the beacon signal will be lost for short periods of time. If the beacon signal is lost, the SQF reading on the DAPT display reads:

```
Beacon  
Lost
```

Be careful that you do not block the front of the feed horn for longer than 10 seconds. If the beacon signal is lost for more than 10 seconds, the satellite modem will most likely revert to coarse pointing mode and you will have to start the pointing process over.

Upon completion of the previous phase, the DAPT display reads:

```
Center 1  
SQF< >s9f
```

This message indicates that the DAPT is capturing and storing the SQF value without the squinter on the feed horn, also known as the *center* value.

1. Press **Advance**. The DAPT display shows a `Wait` message for approximately 15 seconds, then reads:

```
SQNT AZ1  
SQF< >s9f
```

2. Place the squinter on the feed horn in either of the two azimuth positions as explained in *Fine pointing* on page 17, and press **Advance**.

The DAPT display reads `Wait AZ1` while the IDU records the first azimuth measurement. (This process could take up to 15 seconds.)

When the reading is complete, the DAPT display reads:



3. Rotate the squinter 180 degrees to the opposite azimuth position and press **Advance**.

The DAPT display reads *Wait AZ2* while the IDU records the second azimuth reading. (This process could take up to 15 seconds.)

When the difference between the pair of azimuth measurements is within 15 SQF points, the test will pass and the DAPT display will read:

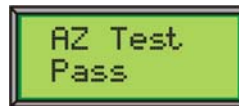

Note: If the azimuth test fails, press **Back** to return to the SQNT AZ1 state and repoint the antenna's azimuth plane.

4. Press **Advance** to proceed to the elevation test. The DAPT display shows a *Wait* message for approximately 15 seconds, then reads:



5. Rotate the squinter 90 degrees to the first elevation position and press **Advance**.

The DAPT display reads *Wait EL1* while the IDU records the first elevation measurement. (This process could take up to 15 seconds.) When the reading is complete, the DAPT display reads:



6. Rotate the squinter 180 degrees to the opposite elevation position and press **Advance**.

The DAPT display reads `wait EL2` while the IDU records the second elevation reading. (This process could take up to 15 seconds.) When the difference between the pair of elevation measurements is within 15 SQF points, the test will pass and the DAPT display will read:



EL Test
Pass



Note: If the elevation test fails, press **Back** to return to the SQNT EL1 state and repoint the antenna's elevation plane.

7. Press **Advance**. The DAPT display shows a `wait` message for approximately 15 seconds, then reads:



Center 2
SQF< >sqf

8. Remove the squinter from the feed horn and press **Advance**. The DAPT displays a `wait` message while the IDU performs the second center measurement. (This process could take up to 15 seconds.) When this center measurement is within 10 SQF points of the Center 1 measurement (taken at the start of the validation phase), the test will pass and the DAPT display will read:



STORE
Results?

9. Press **Advance** for Yes or **Toggle** to return to Pointing Validation mode.

If you press **Advance**, the DAPT prompts you for confirmation that you want to save the results, with the message:



Note: Do *not* disconnect the DAPT until instructed to do so. Disconnecting the DAPT prematurely could cause a loss of all stored data, invalidating the entire pointing process. It could also cause the satellite modem to crash.

10. Press **Advance** to save the pointing validation results, or **Back** to return to the previous state.

If you press **Advance**, the DAPT display reads:



11. Press **Advance** to indicate Yes and complete the pointing process, or **Back** to restart pointing validation.

If you press **Advance**, the DAPT display should read:



This indicates that you have completed the pointing process successfully. The DAPT displays this message for approximately 10 seconds, then displays the IFL voltage to indicate that the pointing process has finished.



Note: Do *not* disconnect the DAPT until the IFL voltage appears. Disconnecting the DAPT prematurely could cause a loss of all stored data, invalidating the entire pointing process.

You may also see:



This message indicates that the satellite modem is downloading necessary software. If you see this message, you must wait until the download process completes and the `Pointing done` message appears, followed by the IFL voltage. Do *not* disconnect the DAPT until the IFL voltage appears. Disconnecting the DAPT prematurely could cause a loss of all stored data, invalidating the entire pointing process.

12. When the IFL voltage appears, disconnect the DAPT and reconnect the receive IFL cable directly to the LNB.
13. Secure all cable connections with dielectric grease and weatherproofing tape as shown in Figure 12.



Figure 12: Weatherproofing the cable connectors

This completes the pointing process.

Troubleshooting

The procedures above outlines the basic pointing process. Should the DAPT display an error message or if you receive unexpected results, use the information in Table 4 below to help you diagnose and resolve the problem. If following the procedures outlined below does not resolve the problem, contact Installer Support.

Table 4: DAPT display messages

Symptom	Indication	Corrective Action
DAPTcomm Down	Display on DAPT when the DAPT is internally in a state where communication with the satellite modem should have already been established, or had been established and was lost for more than 5 seconds. If the DAPT is unable to establish communication with the IDU, DAPTcomm Down appears on the display.	If the DAPT remains in this state, reboot the IDU.
Permanent "COMM Startup" message	IDU is not in pointing mode. Advance button was been pressed before submitting the installation parameters.	At the LUI, verify that the IDU is in pointing mode (refer to Figure 6 on page 12). If the IDU is not in pointing mode, repeat steps 4 - 8 of <i>Entering installation parameters</i> on page 8. If the DAPT does not display the SQF reading (SQF<>sqf) after a few seconds, press the Advance .
Permanent "Logging VoltMeas" message	Cables on the DAPT are not connected properly.	Reconnect the cables to the DAPT in accordance with the connector labels on the DAPT rear panel.
SQF does not go higher than 1	<ul style="list-style-type: none"> • Circular polarization setting is incorrect. • Installation parameters incorrect. • No Rx cable connected between DAPT and LNB, or bad cable used. 	<ul style="list-style-type: none"> • Set the polarization to LHCP or RHCP as indicated on the Terminal Pointing Info screen (Setting for ODU Polarization). • Go to "Modify Installation Parameters" under "Advanced Configuration and Statistics" and use the Installation Reference Sheet to make the appropriate corrections. • Connect/replace the Rx cable between DAPT and LNB.
Low SQF indication	Incorrect installation parameters entered	If incorrect parameters were entered, the modem could be installed in the wrong downlink cell. Go to "Modify Installation Parameters" under "Advanced Configuration and Statistics" and use the Installation Reference Sheet to make the appropriate corrections.
"Center 2" significantly lower than "Center 1" (more than 20 points apart)	Squinter is still on the feed horn.	Remove the squinter from the feed horn and verify the new Center 2 reading in the DAPT display.

Table 4: DAPT display messages

Symptom	Indication	Corrective Action
Find Sys Status X	If the satellite modem enters this phase before pointing was completed, use the Back button (1) to return to Point mode.	In this phase, you must wait for the satellite modem IDU to finish a task.
Find Sys Failed	Error message if cell selection fails. This is a terminal pointing state, since the satellite modem IDU cannot move forward with this error.	Reboot the IDU
Tx Pol Left (or Right)	During cell selection, it is possible that the closest working cell is in an adjacent UL cell that requires flipping the polarizer on the ODU. If a polarization change is needed, the IDU will send commands to the DAPT to indicate which pol setting should be used. For instructions on reversing circular polarization, see the installation guide for the specific antenna model being installed.	Adjust the polarizer to the proper setting, then press Advance to proceed to the next phase.
Beacon Lost	IDU has detected loss of beacon lock. If beacon lock is reacquired within 10 seconds, the pointing process continues. Otherwise, the satellite modem IDU returns to the Pointing state.	This error may occur while you are putting the squinter on the feed horn during fine pointing or validation. You must keep the loss duration under 10 seconds to prevent the satellite modem IDU from going back to the Pointing state.
DAPT not responding	If the DAPT is mistakenly connected to the transmit cable instead of the receive cable, the DAPT is programmed to partially shut down because it is not designed to handle the amount of voltage coming from the transmit cable. In this case, the DAPT backlight shuts off, the buttons do not respond, and the voltage reading in the display is at or near 50 volts.	This error may occur after the DAPT is first connected. Disconnect the DAPT from the transmit cable and connect it to the receive cable.

Acronyms and abbreviations

A

Az – Azimuth

D

DAPT – DiSEqC antenna pointing tool

dB – decibels

DiSEqC – Digital satellite equipment control

E

El – Elevation

F

FSB – Field service bulletin

FSO – Field service office

G

GPS – Global positioning system

I

IDU – Indoor unit

IFL – Intra-facility link

L

LAN – Local area network

LCD – Liquid crystal diode

LHCP – Left-hand circular polarization

LNB – Low-noise block

LUI – Local user interface

M

m – meters

MIP – Megafame information packet

O

ODU – Outdoor unit

R

RF – Radio frequency

RHCP – Right-hand circular polarization

Rx – Receive

S

SNR – Signal-to-noise ratio

SQF – Signal quality factor

T

Tx – Transmit

U

UL – Uplink

W

WAAS – Wide-area augmentation system

A

azimuth

- adjusting 15
- determining coordinates 8
- measuring 18

B

- beacon lock 4
- beacon signal 25, 31
 - losing 25

C

cables

- approved types and maximum lengths 7
- IFL 7, 13, 14, 29, 31

cell selection 31

circular polarization 24, 31

coarse pointing

- description 4
- overview 1
- procedure 13

D

DAPT

- buttons 3
- description 2
- error messages 30
- installing 13

dithering

- see fine pointing

E

elevation

- adjusting 15
- determining coordinates 8
- measuring 19

F

- filters, pointing 5, 14, 19, 21
 - selecting 15

fine pointing 3

- description 5
- overview 1
- procedure 17–24

G

GPS

- description 2
- using 8

I

IFL cables 7, 13, 29, 31

- voltage 14

initial satellite acquisition 4

installation parameters, entering 4, 8

- See also LUI

K

Ka-band antenna 1

L

LUI

- accessing 8
- description 2
- display 8–11

O

ODU power, setting 4

P

peak signal level, finding 5

Point state 14

pointing

- coarse 1, 4, 13
- filters 5, 14–15, 19, 21
- fine 1, 3, 5, 17–24
- requirements 1
- validation 1, 25–29

Pointing mode 4

polarization, circular 24, 31

S

satellite acquisition 4
satellite modem 14, 25, 29, 31
scintillation 5, 14
squinters 17
 attaching 18, 21
 description 3
 types 3, 18
 using 5, 17

V

validation 1, 25–29